

Operator's Instruction Manual
COMPACT PLANER
Models CPM-4, CPM-8, CPM-10



CPM-10



CPM-8



CPM-4

**Gasoline/Electric/Propane
Concrete/Asphalt Planer**



100 Thomas Johnson Drive, Frederick, MD 21702-4600 USA
Phone (301) 663-1600 • 1-800-638-3326
Fax (301) 663-1607 • 1-800-447-3326
Website: www.edcoinc.com • Email: sales@edcoinc.com

Printed in USA
tw ©2005

READ AND UNDERSTAND THE OPERATORS INSTRUCTION MANUAL THOROUGHLY BEFORE ATTEMPTING TO OPERATE THIS EQUIPMENT.



Death or serious injury could occur if this machine is used improperly.

SAFETY MESSAGES

- Safety Instructions are preceded by a graphic alert symbol of DANGER, WARNING, or CAUTION.



Indicates an imminent hazard which, if not avoided, will result in death or serious injury.



Indicates an imminent hazard which, if not avoided, can result in death or serious injury.



Indicates hazards which, if not avoided, could result in serious injury and or damage to the equipment.

GASOLINE/PROPANE POWERED EQUIPMENT



- Engine exhaust from this product contains chemicals known to the State of California to cause cancer, birth defects or other reproductive harm.



- Gasoline is extremely flammable and poisonous. It should only be dispensed in well ventilated areas, and with a cool engine.

- Small gasoline engines produce high concentrations of carbon monoxide (CO) example: a 5 HP 4 cycle engine operation in an enclosed 100,000 cu. ft. area with only one change of air per hour is capable of providing deadly concentrations of CO in less than fifteen minutes. Five changes of air in the same area will produce noxious fumes in less than 30 minutes. Gasoline or propane powered equipment should not be used in enclosed or partially enclosed areas. Symptoms of CO poisoning include, headache, nausea, weakness, dizziness, visual problems and loss of consciousness. If symptoms occur - get into fresh air and seek medical attention immediately.

ELECTRICAL POWERED EQUIPMENT



Extreme care must be taken when operating electric models with water present: Ensure power cord is properly grounded, is attached to a Ground-Fault-Interrupter (GFI) outlet, and is undamaged.

- Check all electrical cables - be sure connections are tight and cable is continuous and in good condition. Be sure cable is correctly rated for both the operating current and voltage of this equipment.
- Improper connection of the equipment-grounding conductor can result in a risk of electric shock. Check with qualified electrician or service person if there is any doubt as to whether the outlet is properly grounded. Adhere to all local codes and ordinances.
- **NOTE:** In the event of a malfunction or breakdown, grounding provides a path of least resistance for the electric current to dissipate. The motor is equipped with a grounded plug and must be connected to an outlet that is properly installed and properly grounded. DO NOT modify the plug provided on the motor. If the plug does not fit the outlet have a qualified electrician install the proper receptacle.
- Switch motor OFF **before** disconnecting power.

- Do not disconnect power by pulling cord. To disconnect, grasp the plug, not the cord.
- Unplug power cord at the machine when not in use and before servicing.

GENERAL INSTRUCTIONS

- Equipment should only be operated by trained personnel in good physical condition and mental health (not fatigued). The operator and maintenance personnel must be physically able to handle the bulk weight and power of this equipment.
- This is a one person tool. Maintain a safe operating distance to other personnel. It is the **operators' responsibility** to keep other people (workers, pedestrians, bystanders, etc.) away during operation. Block off the work area in all directions with roping, safety netting, etc. for a safe distance. Failure to do so may result in others being injured by flying debris or exposing them to harmful dust and noise.
- This equipment is intended for commercial use only.
- For the operator's safety and the safety of others, always keep all guards in place during operation.
- Never let equipment run unattended.



- Personal Protection Equipment and proper safety attire must be worn when operating this machinery. The operator must wear approved safety equipment appropriate for the job such as hard hat and safety shoes when conditions require. Hearing protection **MUST** be used (operational noise levels of this equipment may exceed 90db). Eye protection **MUST** be worn at all times.



Keep body parts and loose clothing away from moving parts. Failure to do so could result in dismemberment or death.

- Do not modify the machine.
- Stop motor/engine when adjusting or servicing this equipment.



Maintain a safe operating distance from flammable materials. Sparks from the cutting-action of this machine can ignite flammable materials or vapors.

DUST WARNING



Some dust created by power sanding, sawing, grinding, drilling, and other construction activities contains chemicals known to cause cancer, birth defects, or other reproductive harm. Some examples of these chemicals are:

- Lead from lead-based paints, and
- Crystalline silica from bricks and concrete and other masonry products.

Your risk of exposure to these chemicals varies depending on how often you do this type of work. To reduce your risk: work in a well ventilated area, use a dust control system, such as an industrial-style vacuum, and wear approved personal safety equipment, such as a dust/particle respirator designed to filter out microscopic particles.



Equipment Instruction Manual

EDCO Models CPM-4, CPM-8, CPM-10

Table of Contents

<u>Section</u>	<u>Page Number</u>
Safety Messages.....	2
Table of Contents and Specifications.....	3
Safety Guidelines.....	4
Operating Instructions.....	5-8
Cutting, Drum Removal/Replacement.....	8-12
Dry Grinding.....	13
What to expect from your EDCO product, Maintenance Instructions.....	14-18
Maintenance Schedule.....	19
Limited Equipment Warranty.....	back cover

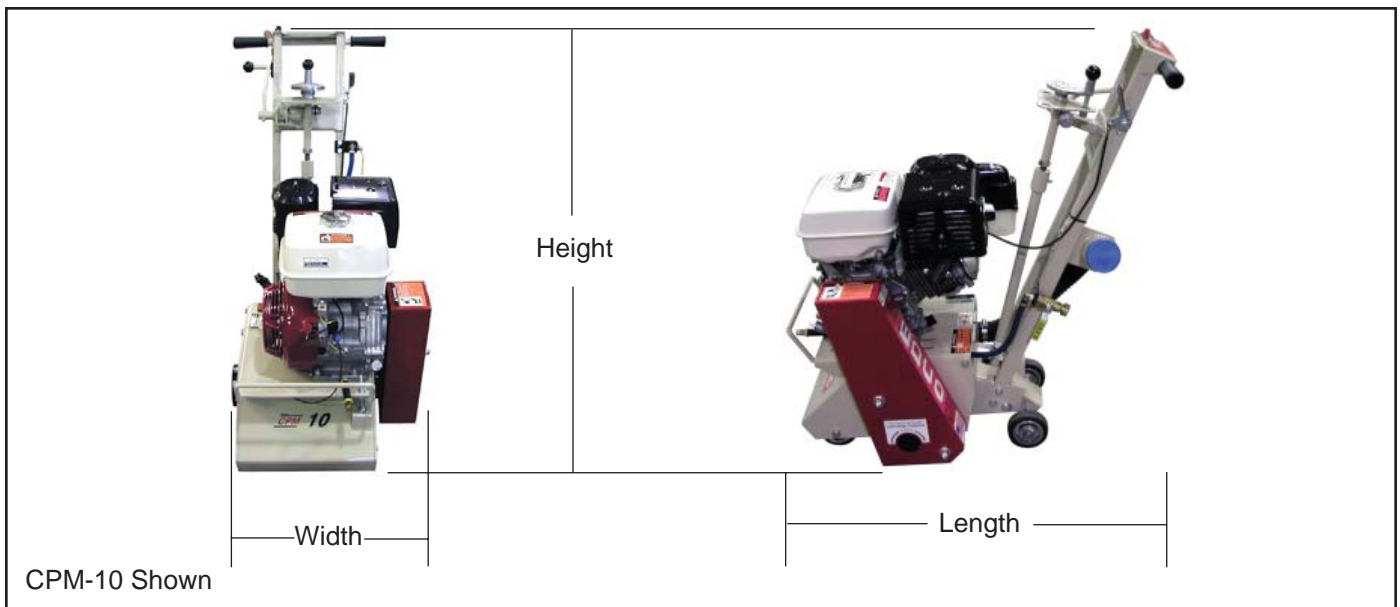

Figure 1

HOW TO ORDER REPAIR PARTS

To insure product safety and reliability, always use genuine EDCO replacement parts when making repairs to the equipment.

When ordering parts, please specify the MODEL and SERIAL NUMBER of the machine as given on the NAMEPLATE. In addition, give part number, description and quantity as listed on the parts list.

Please note: Due to improvements and changes in the equipment the illustrations shown may be different from the actual machine.

Toll Free: Voice 1-800-638-3326 • Fax 1-800-447-3326

Specifications and dimensions are approximate and subject to change.

Model	CPM-4	CPM-8	CPM-10
Length	46"/117cm	35"/89cm	42"/107cm
Width	17"/43cm	19"/47cm	23"/58cm
Height	38.5"/98cm	40"/101cm	41"/104cm
Weight	185lbs/84kg	214lbs/97kg	270lbs/123kg



100 Thomas Johnson Drive, Frederick, MD 21702-4600 USA
 Phone (301) 663-1600 • 1-800-638-3326
 Fax (301) 663-1607 • 1-800-447-3326
 Website: www.edcoinc.com • Email: sales@edcoinc.com



Read and understand the *Operator's Manual*,
and the *Engine/Motor Manufacturer's Owner's Manual*
before operating this equipment.



Death or serious injury can result if this machine is used improperly.



Safety Guidelines



Eye and ear protection must be worn at all times when this machine is in use. During normal use, sound levels exceed 92dB. Use only ANSI approved safety glasses to help prevent eye injury. Every-day eyeglasses have only impact resistant lenses; they are NOT safety glasses.



Operator must wear appropriate clothing and footwear. Do not wear loose clothing or jewelry that can get tangled or caught in moving parts. Steel toe safety shoes should be worn.

- Maintain the machine in safe operating condition with all guards in place and secure, all mechanical fasteners tight, all controls in working order and the machine configured for the job application. Be sure all safety decals can be clearly read and understood. Replace damaged or missing decals immediately.
- The CPM-4-8 and 10 Planers are designed to plane flat, horizontal concrete or asphalt slabs. They may be called Planers, Mills, Grinders or Scarifiers and may be equipped with gasoline, propane engines or electric motors. They are designed to be operated by a single operator from a position at the rear of the equipment.
- Keep a safe operating distance to other personnel in the area and never leave the machine running unattended.
- Avoid deck inserts, pipes, columns, openings, electrical outlets, or any objects protruding from slab surface.
- Never operate this machine while under the influence of drugs, alcohol or when taking medications that impair the senses or reactions, or when excessively tired or under stress.



For Electric Models:

Electric motors must be properly grounded at all times. Check the outlet box to be sure the electrical service is properly grounded. Be sure adequate power is available. Insufficient power will cause a motor to overheat and burn out. Use only grounded extension cords correctly sized for the current draw and voltage drop (amp rating and length). Never use frayed, damaged, taped or under rated extension cords.



Electrical shock could result in death or serious injury to the operator and damage to the equipment.

For Gasoline or Propane Models:

Poisonous exhaust gas. Do not operate gasoline or propane powered equipment without adequate ventilation. Carbon monoxide is an invisible, odorless gas that can kill. NEVER REFUEL A HOT ENGINE OR AN ENGINE WHILE IT IS RUNNING. Only refuel a cool "stopped" engine in a well-ventilated area. Properly clean any spilled fuel before starting the engine.

Safety warnings and guidelines do not by themselves eliminate danger. They are not given as substitutes for proper accident prevention and good judgement.

Operating Instructions

- | | |
|--|---|
| 1. Cutter Head Lever | 8. Fuel Tank * |
| 2. Depth Control Knob | 9. Emergency Stop Switch Lanyard (CPM-10) * |
| 3. Emergency Stop Tether (CPM-10) Stop button on (CPM-4 & CPM-8) * | 10. Easy Lift Handle |
| 4. Cushioned Handles | 11. Fuel Lockoff Solenoid Toggle For Propane Models Only. (Not Shown) * |
| 5. Ignition Switch (Position will vary) * | 12. MultiVac port (Not Shown) |
| 6. Throttle Control * | |
| 7. Water Hook Up | |

* Not on Electric models

NOTE: Controls are similar on all models.

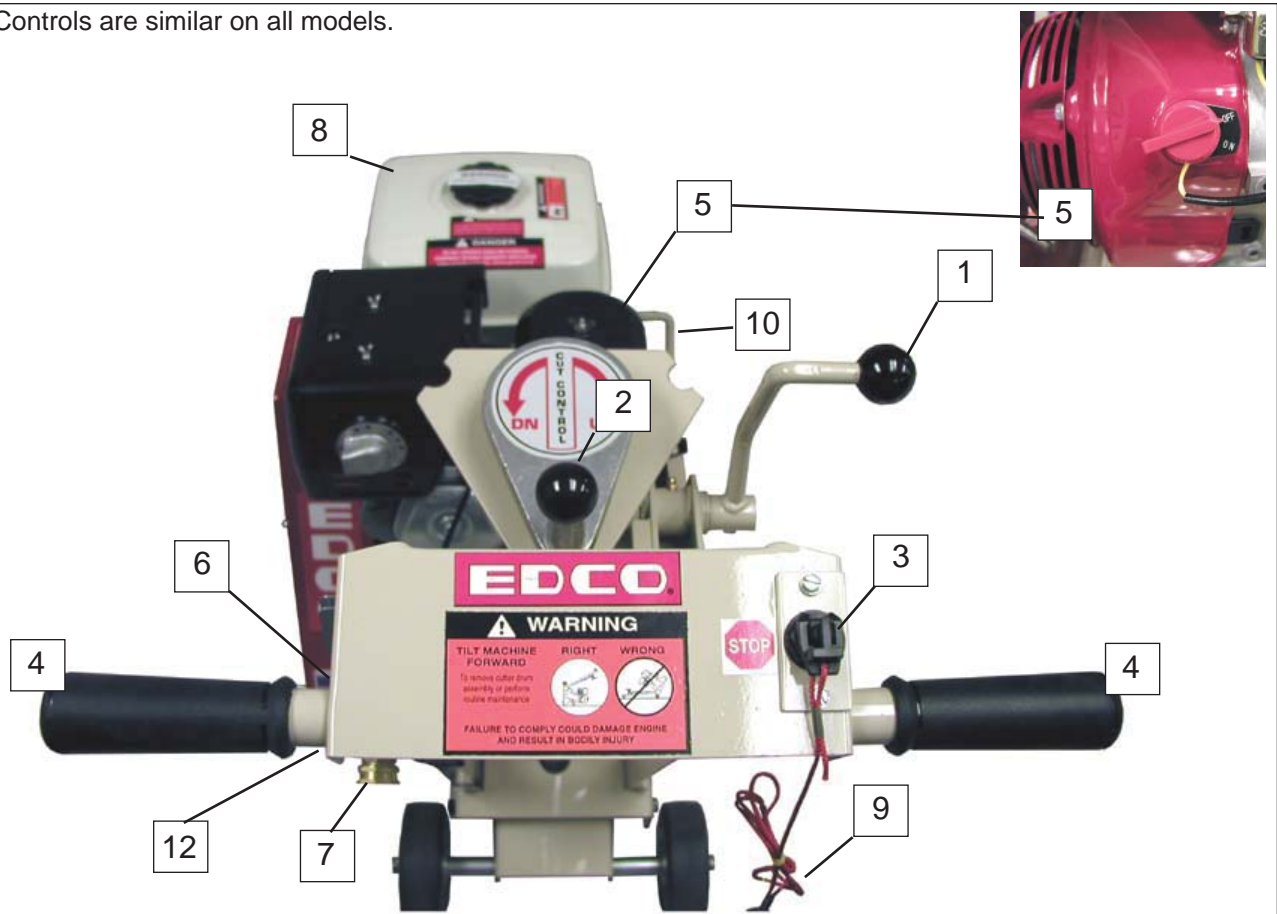

Figure 2



100 Thomas Johnson Drive, Frederick, MD 21702-4600 USA
 Phone (301) 663-1600 • 1-800-638-3326
 Fax (301) 663-1607 • 1-800-447-3326
 Website: www.edcoinc.com • Email: sales@edcoinc.com

Printed in USA

TMW ©2005

Page 5

CPM-4-8-10 OPERATING INSTRUCTIONS

When using Hi-carbon steel or Tungsten Carbide cutter wheels:

IMPORTANT!

Read the engine manufacturer's manual, familiarize yourself with engine start procedures.

BEFORE STARTING THE ENGINE: *Gasoline models only

Be sure that the cutter drum assembly has been properly installed and the cutter drum shaft is in place and secured.

1. Select a level place at the job site. Set the "disengage lever" in the full DOWN position. Refer to (Figure A).
It is most important to determine the position of the cutter wheels as they relate to the slab or floor surface. If the drum assembly is filled with cutters, the cutter wheels will most likely contact the slab when the "disengage lever" is lowered. Refer to (Figure B).
Turn the "depth adjustment crank" UP until the cutter wheels are clear of the slab. Refer to (Figure A). Follow these instructions each time before the engine is started to prevent accidental damage to the slab.
2. Raise the "disengage lever" to the full UP position. DO NOT force the lever. If resistance is felt, turn the "depth adjustment crank" DOWN one or two turns. This will allow the "disengage lever" to reach its normal full UP position. Refer to (Figure C).
3. Check level of oil in engine crankcase (engines are usually shipped dry, oil must be added as per engine manufacturers instructions). *
4. Check fuel level (follow engine manufacturers instructions). *
5. Be sure all guards (belt, motor, cutter wheel) are in place and secure.
6. Vacuum hose port should have hose attached or cap installed to control dust generated during the cutting operation.
7. Locate engine on/off switch, if the engine is so equipped. On some engines the throttle control is also the engine shut-off switch. Familiarize yourself with this operation. *
8. All **EDCO** gasoline engine operated planers are equipped with a STOP switch, usually located on the handle. Use this switch for emergency engine shut-off. *
9. Cold engine starting: Be sure fuel line valve is open. Set choke (separate lever on some engines - others have choke as part of throttle control). Open throttle (full to engage choke) 3/4 to full on engines with a separate choke. Turn engine ignition switch ON. Be sure emergency STOP switch is ON. *
10. Before starting determine that the recoil starter assembly turns freely, starter rope pulls easily and the rope retracts properly. *

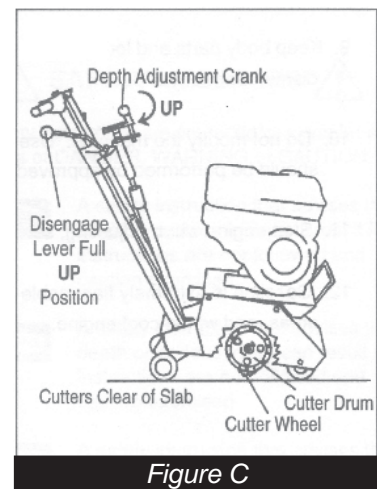
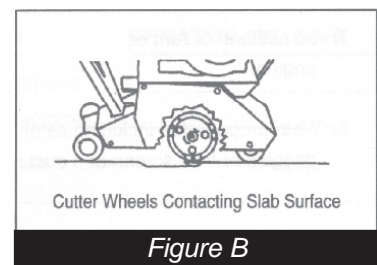
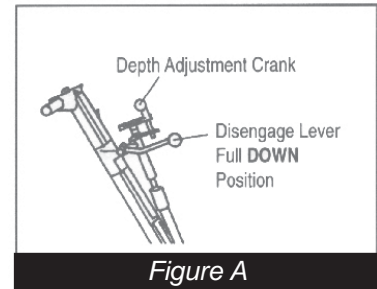

Before Starting the Machine:

- Perform a visual inspection of the entire machine and all daily maintenance according to the *Maintenance Schedule* on page 15.
- Locate and be familiar with all engine/motor and operating controls .
- For Gasoline models, obtain the *Engine Manufacturer's Owner's Manual*. Read it and understand it before continuing. Follow the engine manual for break-in instructions.
- Use the correct cutters for the job. Be sure cutter drum is balanced, the number, size and type of cutter wheels are correct and the cutter drum shaft is locked and secured.
- Be sure all fasteners are tight and secure, check for signs of metal cracking or fatigue, inspect for damage to electrical wiring, damage to fuel lines, check bearings, etc.
- Be sure all guards are in place. Do not operate unless cutter drum guard is in place and secure.
- Inspect work area to determine the presence and location of deck inserts, pipes, columns and objects protruding from the slab surface so that they may be avoided during operation.

Starting the Engine/Motor:

For Electric Models:

- CAUTION** • Be sure the "OFF" button is depressed on the motor starter box.
- Hook up the correct voltage/phase electrical power source by plugging into the connector provided. If the cord does not mate with the connector, consult a qualified licensed electrician before continuing.
 - Verify that the electrical current being supplied is the proper voltage and phase required to run the equipment
 - Check motor rotation. Cutter drum rotation on the model CPM machines is "down cut." DO NOT use if drum rotation is incorrect - have a qualified electrician make the necessary change in the main control panel or motor connection box.

For Gasoline Models:

- Consult the *Engine Manufacturer's Owner's Manual* and follow the directions for starting the engine and allow the engine to warm up.

For Propane Models:

DANGER Propane is extremely flammable.

- Propane models use a vapor withdrawal system. Operate the propane engine much like you would the gasoline model. Be sure propane tank (cylinder) is positioned correctly. (Figure 3)
- Turn on main fuel valve at propane tank. (Figure 3)
- Check all connections for tightness and leaks. If you detect an odor, IMMEDIATELY shut off the main fuel valve and consult a qualified LP-gas service person or EDCO directly.

DANGER

DO NOT operate gasoline/propane powered equipment without adequate ventilation. Carbon monoxide is an invisible, odorless gas that can kill.





NEVER check for propane leaks using an open flame. Instead, use a leak-testing solution. NEVER allow propane fumes to escape in a closed area; propane is heavier than air and will “settle.”

- To start this propane powered equipment, open the main fuel valve located on the propane tank (Figure 3). Open the throttle wide open and start the engine.

NOTE: Always turn off the main fuel valve on the propane tank when equipment is not being used (Figure 3).

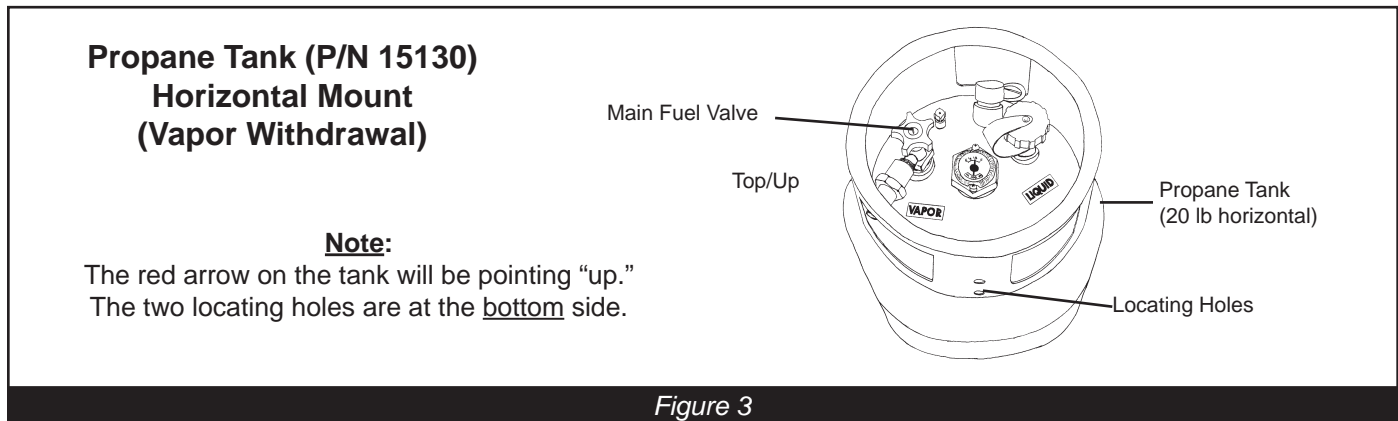

CUTTING

Starting the Cut:

- Slowly lower the cutter head to the slab surface with the cutter head lever. (Figure 2, Item 1) & (Figure4)
- Lift the knob of the Depth Control to unlock and turn the hand wheel slowly until the cutter head contacts the slab (you will hear the sound of the cutter wheels contacting the slab). Continue adjusting the depth of cut until the desired depth is reached; max depth of cut 3/8” (9.5 mm).
- Use an Industrial Vacuum Dust Control System for dry planing operations.
- Water hookup also available.

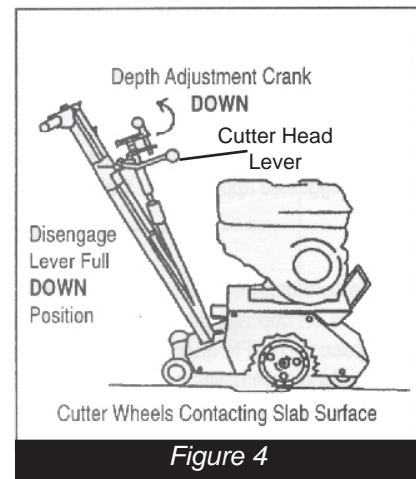

To Stop Cutting:

- Move cutter head control lever to raise cutter head assembly above slab surface.
- For gasoline and propane models, close throttle and turn the ignition switch to the “off” position.
- For electric models, depress the “OFF” button.

After Cutting:

- At the end of the day, clean the entire machine after it has cooled. Check for worn or damaged cutters and perform any required maintenance. See Maintenance Schedule and Instructions on page 13.
- If water was used for dust control - - - clean slurry under machine before it dries.

Cutting Heads / Drums:

- Drum assembly revolves at approximately 1800 R. P. M.; Model CPM-10 is a “down-cut” planer, Model CPM-8 is a “down-cut” planer and Model CPM-4 is an “up-cut” planer. Depth of cut is completely determined by the material to be cut, horsepower of the engine/motor and spacing of the cutter wheels on the cutter head.
- All cuts should be started from a stationary position - when the cutting depth is reached the planer should then move forward.
- The engine should not labor. Run at full throttle and adjust forward speed to fit the work being performed. Very hard concrete will have to be cut at a slower pace than asphalt or deteriorated surfaces.
- If it is necessary to make deep cuts - make several shallow cuts to achieve the desired depth. If the cutting depth is set too deep the cutter wheels will not be able to absorb the shock and damage to the equipment will result.
- The cutter wheels have an oversized arbor hole. This “play” is needed to absorb some of the shock of the cutter contacting the concrete.
- Cutting speed is directly proportional to the amount of material to be removed in one pass; an example - cutters spaced on 1” centers will penetrate to a greater depth than those spaced at 1/2” centers, and the planer will move forward faster. Most of the material in the path of the cutting head will be removed either by the cutters themselves or through the natural hammering action and spalling of the material being cut. A later pass with cutters spaced closer together will remove the ridges.

To Reach Maximum Depth in Concrete:

- It is best to make several passes - increments of 1/8” or even less if surface is extremely hard.
- Use coarse (wide spacing) for initial passes. Complete job with medium spacing. Never use a fine spaced cutter head to cut deeper than 1/8”.
- Some concrete slabs, especially if they are covered with water a good deal of time or if they have been treated with hardeners, develop an extremely high surface strength.
- Material removal depth should not exceed 1/8” per pass thus requiring several passes to reach the desired depth of cut.

To Cut Asphalt:

- This surface is usually easy to penetrate - depths of 1/4” can be reached using medium spacing. Let the job guide your selection of cutter spacing. Deep cuts require wide cutter spacing. Asphalt will usually break out between cutters and a fairly uniform clean cut is the result.

Note: Specific information on asphalt cutting is available upon request.

Fine Cutting:

- This assembly should be used for very shallow or cleaning operations. Check with dealer for special cutter wheels for removal of paint build-up or similar surface coatings.



100 Thomas Johnson Drive, Frederick, MD 21702-4600 USA
 Phone (301) 663-1600 • 1-800-638-3326
 Fax (301) 663-1607 • 1-800-447-3326
 Website: www.edcoinc.com • Email: sales@edcoinc.com

Printed in USA

TMW ©2005

Page 9

CPM-4 DRUM REMOVAL / REPLACEMENT CPM-4 and CPM-8 EDGER ATTACHMENT



To remove or replace drum assembly on the CPM-4 remove the two (2) bolts circled securing the drum cover plate in the photo on the left.



Next remove the socket head screw as shown in the photo on the left.



Slide the drum out as shown in the photo on the left.

Reverse procedure to reassemble.

CPM-8 DRUM REMOVAL / REPLACEMENT

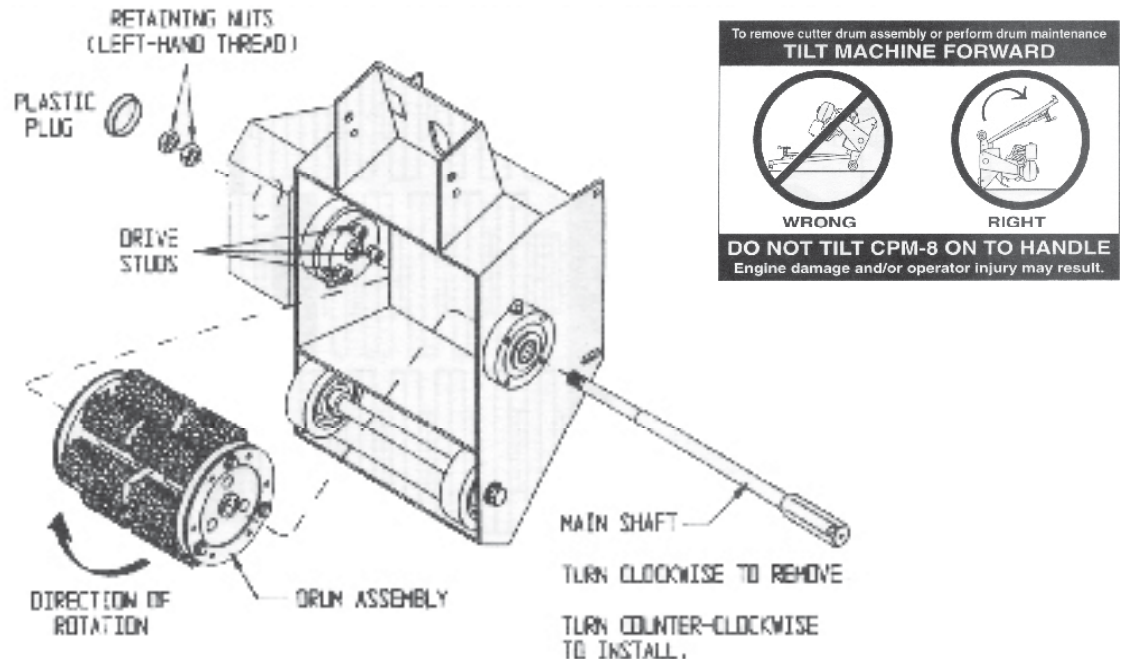

1. Remove plastic plug from belt guard, set aside for later use.
2. Use a socket wrench to loosen *left-hand thread* retaining nuts. Be sure the socket is over the outer retaining nut only. The outer retaining nut has to be loosened first and removed, then remove the second retaining nut, use another wrench to hold the other end of the shaft during this procedure.
3. Be careful not to damage threads on end of shaft when removing or installing the drum. Support the weight of the drum to minimize the possibility of damage.
4. With the *left-hand thread* retaining nuts removed, use a socket wrench to turn the other end of the shaft in a *clockwise* direction for removal. Support drum during shaft removal so the drum will not fall when the shaft is removed, possibly causing damage to machine and personal injury.
5. Once the drum is removed, maintenance and/or cutter replacement can be performed.
6. Reverse this procedure for reassembly insuring the drive studs are lined up with drive holes in drum before inserting the main shaft. Be sure to install plastic plug removed in step #1.



CPM-10 DRUM REMOVAL / REPLACEMENT



To remove or replace the drum assembly on the CPM-10 remove the four (4) bolts circled securing the bearing plate in the photo on the left .

NOTE: Bearing grease point.



Next remove the bearing plate as shown in the photo on the left.



Slide the drum out as shown in the photo on the left.

Reverse procedure to reassemble.

DRY GRINDING

Dry Grinding:



Dry Grinding creates a large volume of airborne dust. For health reasons, the operator should wear an applicable respirator. The dust may contain chemicals known to cause serious illnesses, including Silicosis - a fatal disease of the lungs. Check the chemical properties of the material to be removed and follow all EPA/OSHA regulations.

- An Industrial vacuum, capable of handling high volume of fine dust, such as the VAC-160 (Figure 5), should be used when dry grinding with this machine. If the material being used is hazardous or contains Silica - the vacuum unit should be capable of removing Respirable Silica and hazardous particles of less than 3 microns and if necessary, have the capability to be equipped with a HEPA filter.
- Most standard drum type units use a paper bag filter. The dust created during grinding is extremely fine and will clog the filter bag of these units and eventually damage the vacuums motor. In addition, damage to the CPM-4-8-10 engine could occur.
- The collected debris and filters should be disposed of according to procedures that comply with current EPA/OSHA standards.



Figure 5

FOR YOUR SAFETY AND WELL BEING

DANGER

DO NOT operate gasoline/propane powered equipment without adequate ventilation. Carbon monoxide is an invisible, odorless gas that can kill.

To remove cutter drum assembly or perform drum maintenance
TILT MACHINE FORWARD



WRONG



RIGHT

DO NOT TILT CPM-8 ON TO HANDLE
Engine damage and/or operator injury may result.



100 Thomas Johnson Drive, Frederick, MD 21702-4600 USA
Phone (301) 663-1600 • 1-800-638-3326
Fax (301) 663-1607 • 1-800-447-3326
Website: www.edcoinc.com • Email: sales@edcoinc.com

Printed in USA

©2005

Page 13

What to Expect from your CPM-4, CPM-8, CPM-10 EDCO Concrete Planer

The CPM-4-8-10 EDCO concrete Planers were designed to remove material from the surface of concrete slabs. The material may consist of excess concrete, coatings, contaminants such as industrial debris, sealer, paint, production line spill and virtually any foreign substance that creates a safety or health hazard on walks, passageways or floor surfaces.

The EDCO planers are primarily used for surface preparation in commercial and industrial buildings. The machine's total weight is an advantage when used on upper floors where lbs per sq. feet is an important factor. We have kept the overall width to less than 36 inches (91 cm) to allow for passage through most commercial doorways.

Since the maximum depth of cut is 1/2" (2 cm) in increments of 1/16" to 3/16", it is not suited for removal of very hard concrete such as the kind found on roads, bridge decks or runways. This work is best accomplished by heavy duty milling machines built for that purpose.

The basic mechanical structure consists of a fabricated steel frame, a power source - electric, gasoline, or propane (an air motor can also be adapted), and a rotating drum like cutter head that can be raised or lowered to a chosen depth by the operator.

The CPM-4 model is designed with an "up-cut" rotation of the cutter drum assembly, consequently a milling type action occurs which is more efficient than the "down-cut" found on other manual units. The CPM-8 and CPM-10 are down-cut machines.

The push units require very little manual labor to operate - the operator controls speed, forward and reverse directions. Note that it will cut in forward or reverse directions.

The 4" to 10" inch wide drum assemblies consist of a welded cage holding 4, 6 or 8 hardened shafts - locked in place during operation and removable when replacing cutters.

Several styles and sizes of cutter are available. All types of cutters may be used on all sizes of drum assemblies. Cutters vary in size - 2 3/8" for light removal, 3" diameter for longer life. Additional cutter wheel specifications can be found on literature and price lists.

The efficiency of the planer is determined by 3 factors - the hardness and type of surface to be removed, the type of cutting tool and the power behind the cutters.

Since the hardness of the surface cannot be changed and the cutter type is limited to present state of the art material and the power source is fixed - there may be conditions that are beyond the capability of the planer. To exceed these limits will only cause problems. Cutter life will be shortened drastically, excessive vibration will most likely cause the scarifier to self destruct.

EDCO cannot accept responsibility if the conditions found on the job site exceed the ability of the equipment to meet the contractors expectations. It is the obligation of the purchaser, user or renter to determine the compatibility of the planer with the job to be performed.

We at EDCO are prepared to assist the user. We can provide technical information and comparison data on jobs of a similar nature. Given information on the project we can advise the contractor which tools, in our opinion, will suit the job best, approximate production rates and possibly arrange a demonstration or suggest an alternative method or equipment.

EDCO concrete planers, when properly used, will perform efficiently and economically, but as with all "demolition" equipment, unless proper maintenance is provided they tend to wear out faster than other mechanical devices.

It is important that each job be considered individually. Testing should be carried out and a determination made if the project is feasible under the circumstances. In those instances where no other alternative is available, various changes in procedure can be tried - shallower cutting depth, slower forward speeds, spacing of cutters changed - extra weight added. We do not guarantee life of cutters, depth of cut, life of equipment (except for workmanship). Equipment of this type is capable of self destruction through misuse or abuse and the owner/operator is the vital component that can mean success or failure of the project.

Our technical information has been obtained from years of experience on all types of job sites and we will gladly share this information with you. New materials are constantly being introduced - concrete is made harder with additives, chemicals and new curing techniques. We try to keep up with these changes, it's a never ending job for us and we need your cooperation to provide us with accurate job site conditions and information.



**Refer to the CPM-4, CPM-8, CPM-10 Assembly Instructions
booklet for suggested Cutter Drum setups.**

Cutter Wheels

Use only EDCO approved cutter wheels. Cutter wheels for all application are available - sizes and types vary. Complete information is available from EDCO.

Hi Carbon Cutters:



CP-404: 2-3/8" diameter -1" ID x 3/16" max. depth of cut - 1/2" - hi-carbon cutters - use on concrete 3500 PSI or less.



CP-404P: Same as above, except teeth are pointed to aid in removal of paint or similar surface material - points wear and become flat. When this happens, use as you would standard CP-404.

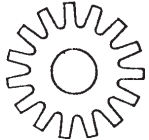

CP-405: 3" diameter - 1" ID x 3/16" - max. depth 3/4" - hi-carbon steel cutters - use on concrete 3500 PSI or less.

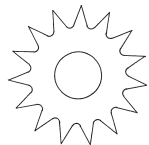

CP-405P: Same as above, except teeth are pointed to aid in removal of paint or similar surface material - points wear and become flat. When this happens, use as you would standard CP-405.

Genuine EDCO Tungsten Carbide Cutters are colored blue:

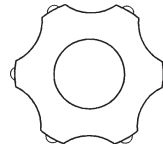

CP-404TV: 2-1/8" OD x 1" ID x 1/4" thk 6 point, tungsten carbide inserts. Use for long life and fast removal of concrete, asphalt or coatings.

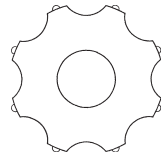

CP-408TV: 3-1/8" OD x 1 3/16" ID x 5/16" thk 8 tungsten carbide inserts. Heavy duty cutter with oversized inner diameter. Maximum cutter shaft diameter 1". Heavy removal of concrete, asphalt or

Spacers:



CP-403: Hardened steel spacers for use with all cutter wheel set ups.

Figure 6

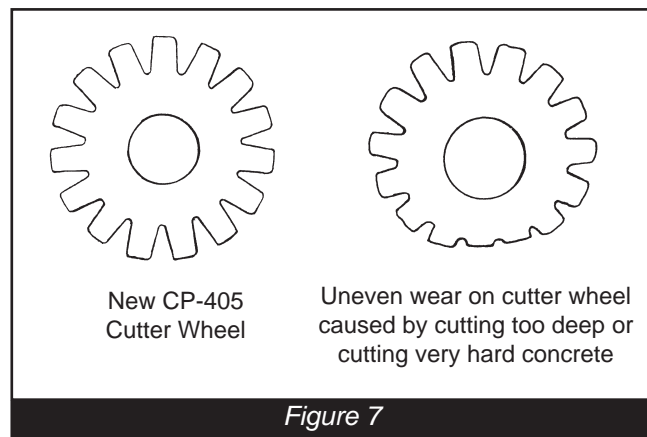

Figure 7



TYPICAL DRUM SET-UPS

Surface preparation
six shaft drum CPM-4



Surface preparation
six shaft drum CPM-8

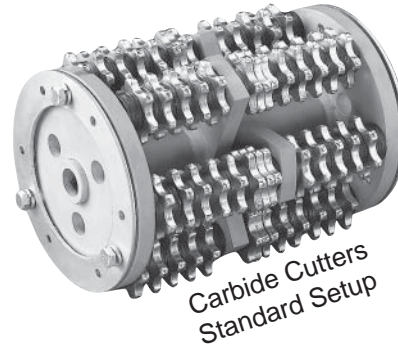

Surface preparation
six shaft drum CPM-8



Surface preparation
eight shaft drum CPM-10

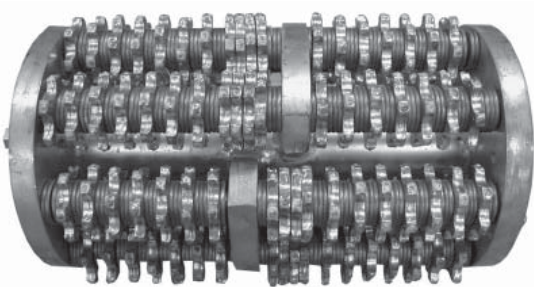

Grooving six shaft
drum CPM-10

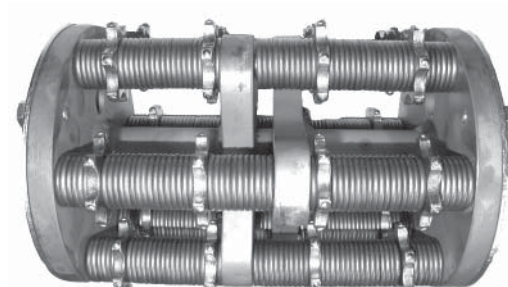

WARNING

Remove spark plug lead on gasoline/propane engine models or disconnect the supply voltage connector on electric models before performing any maintenance. Disconnect the power cord at the machine.

WARNING

Maintenance Instructions

Refer to the Engine/Motor Manufacturer's Owner's Manual for maintenance information specific to the engine/motor used.

CAUTION

Never work on or under equipment without first securing the equipment to prevent it from moving or falling. Always work on a flat and level surface.

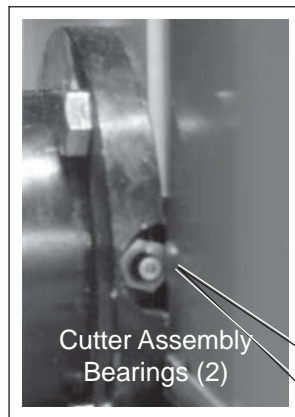

Cutter Assembly Bearings (2)

IMPORTANT!
Grease cutter assembly bearings (2 ea) after every 4 hours of use.



Depth Control Grease point all models.

Grease Depth Control grease point every 40 hours.



CPM 8 & 10

Jacking Bolt

Cutter assembly bearings (2)



CPM 4



CPM-4-8-10 MAINTENANCE INSTRUCTIONS

Important!

- Check oil level before operation. Change engine oil and filter according to engine manufacturers recommendations.
- Clean air filter element daily.

Belts:

- On new equipment, and after replacing a set of belts, they should be re-tensioned after the first four hours of use.
- New belts will be stiff and will loosen with use. Proper belt tension must be maintained to transmit the engine/motor power to the cutting drum. Slipping belts will overheat, belt life will be shortened and the cutting speed limited. Over tensioned belts will shorten belt and bearing life.
- Damaged, stretched or excessively worn belts should be replaced with a complete set. ***DO NOT*** mix new and used belts, doing so will only shorten the life of new belt(s) and limit power transfer from the engine/motor to the cutting drum. This will have a definite impact on machine efficiency and production rate.
- To tension belts, loosen motor mounting hardware slightly. Use the jacking bolt to adjust the engine/motor until the belts are tight. Re-torque the engine/motor mounting hardware.

ENGINE AIR FILTER GASOLINE/PROPANE MODELS ONLY

Engine Air Filter:

- Inspect the air filter (*Figure 8*) for excess dust, dirt or damage before the engine is operated. More often if operating in a extremely dusty environment.
- Operating the engine with a damaged or dirty air filter, or without an air filter, will allow dirt to enter the engine causing premature engine wear which is not covered under the engine manufacturer's warranty.
- Follow the engine manufacturer's procedures for keeping filters in good condition.

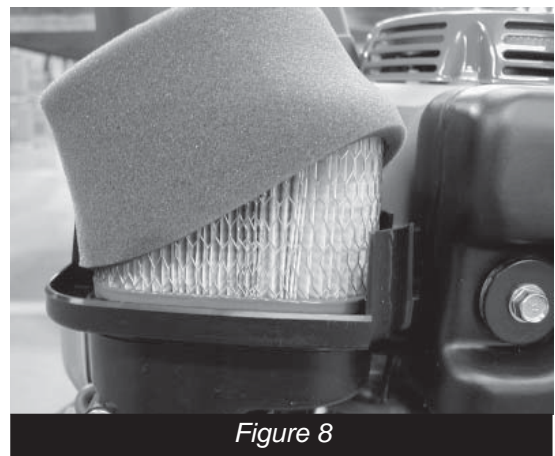

Figure 8

Maintenance Schedule



Repairs are to be done
by authorized EDCO
Dealers only.



Read and follow instruc-
tions in the engine owner's
manual.

All maintenance to be performed by qualified personnel.	Before Operation	Every 4 Hours	Daily	Every 40-50 Hours of Operation	As Required	Every Cutter Change
Visual Inspection of Entire Machine	X					
Check Engine Oil*	X					
Cutter Shaft Wear (bushings, drum)	X					
Check cutters for uneven wear	X					
Grease Cutter Assembly Bearings		X				
Clean Air Filter Element*			X			
Clean Dust & Dirt Off Machine			X			
Change Engine Oil* (Refer to engine manual)				X		
Grease Wheel Bearings				X		
Belt Tensioning					X	
Check Cutter Shaft and Bushings						X

* Gasoline and propane models only.



100 Thomas Johnson Drive, Frederick, MD 21702-4600 USA
Phone (301) 663-1600 • 1-800-638-3326
Fax (301) 663-1607 • 1-800-447-3326
Website: www.edcoinc.com • Email: sales@edcoinc.com

Printed in USA

TMW ©2005

Page 19

LIMITED EQUIPMENT WARRANTY

Equipment Development Company, Inc. herein referred to as EDCO warrants that each new unit manufactured by EDCO to be free from defects in material and workmanship in normal use and service for a period of (1) one year (except in the case of the cutter drum assembly on all model concrete asphalt planes, in which case the warranty period shall be 90 days) from date of shipment to the original buyer or equipment rental center owner.

EDCO will, at its option, repair or replace, at the EDCO factory or at a point designated by EDCO any part, which shall appear to the satisfaction of EDCO inspection to have been defective in material or workmanship.

This warranty, does not apply to failure occurring as a result of abuse, misuse, negligent repairs, corrosion, erosion, normal wear and tear, alterations or modifications made to the product without express written consent of EDCO: or failure to follow the recommended operating practices and maintenance procedures as provided in the products operating and maintenance manuals.

This warranty does not obligate EDCO to bear any transportation charges in connection with the replacement or repair of defective parts. This warranty does not obligate EDCO to bear any expense for travel time or of personnel in connection with any service calls.

Accessories or equipment furnished and installed on the product by EDCO but manufactured by others, including but not limited to engines, motors, electrical equipment, transmissions, etc., shall carry the accessory manufacturers' own warranty.

THIS WARRANTY IS IN LIEU OF ALL OTHER WARRANTIES, EXPRESSED OR IMPLIED, OR STATUTORY, INCLUDING ANY WARRANTIES OF MERCHANTABILITY OR OF FITNESS FOR A PARTICULAR PURPOSE.

LIABILITY LIMITATIONS

The remedies of the user set forth under provisions of warranty outlined above are the exclusive and total liability of EDCO with the respect to their sale or the equipment and service furnished hereunder, in connection with the performance or breach thereof, or from the sale, delivery, installation, repair or technical direction covered by or furnished under the sale, whether based on contract, warranty, negligence, indemnity, strict liability, or otherwise shall not exceed the purchase price of the unit of equipment upon which such liability is based.

EDCO will not in any event be liable to the user, any successors in interest or any beneficiary or assignee relating to this sale for any consequential, incidental, indirect, special or punitive damages arising out of this sale or any breach thereof, or any defects on, or failure of, or malfunction of the equipment under this sale based upon loss of use, lost profits or revenue, interest, lost goodwill, work stoppage, impairment of other goods, loss by reason of shutdown or non-operation, increased expenses of operation of the equipment, cost of purchase or replacement power of claims of users or customers of the user for service interruption whether or not such loss or damage is based on contract, warranty, negligence, indemnity, strict liability, or otherwise.

EDCO reserves the right to modify, alter and improve any part or parts without incurring any obligation to replace any part or parts previously sold without such modified, altered or improved part or parts.

No person is authorized to give any other warranty or to assume any additional obligation on EDCO's behalf unless made in writing and signed by an officer of EDCO.

Equipment Development Company, Inc.

USE ONLY GENUINE EDCO PARTS AND ACCESSORIES
For your own safety, the safety of others and the life of your machine

